

# B-SMART<sup>®</sup> SERIES

**PRESS BRAKE**  
+ INDUSTRY 4.0



## STANDARD

- 3 Axis CNC:
  - + Y1, Y2 precision ram positioning
  - + X Axis Back Gauge
- Large trio of value:
  - + Large open height
  - + Large stroke
  - + Large throat depth
- Back Gauge - motorized & linear guide & ball bearing system
- Back Gauge Fingers - height adjustable
- Safety laser with manual F. AKAS II M-FPSC-B-C
  - + safety covers with switch
- Delem DA-53T CNC control unit
- Manual crowning
- Clamping:
  - + American/European section-style box punch clamps
  - + American-only style punch clamp available at no charge
- Quick-set sliding front sheet support arms with full-length linear guide, tilting stop and T-slot (front gauge squaring, etc.)
- Adjustable height suspension control unit arm
- Protective covers (side and rear safety doors)
- Rear work light
- World-class hydraulic and electronic components that are easily replaceable (parts stocked by us or available off-the-shelf from your local supplier):
  - + Hydraulic blocks and valves (Hoerbiger)
  - + Electronics system (Siemens, Schneider, Mitsubishi)
- High-yield plate construction
- Hydraulic Oil (up to 250 Ton machines)

## OPTIONAL

- CNC R Axis
- Delem DA-58T CNC control unit with 2D graphics, includes a seat of profile-T off-line software
- Safety laser with SICK C 4000 (only for tandem) + steel protective covers
- Adaptive bending sensors (angle measurement)
- Top tool American or European
- Bottom tool American or European
- Hydraulic tooling clamping systems
- Quick release clamping
- Universal die blocks
- CNC controlled motorized crowning
- Extended back gauge stroke & back protection with light barrier
- Oil coolant
- Very reasonable tooling packages available (multi-V tooling)
- Additional finger blocks
- Additional sliding front arms
- Tandem, Trio, Quad configuration



# B-SMART

B-SMART SERIES	STANDARD MACHINE CHARACTERISTICS											
	BENDING FORCE	BENDING LENGTH	DISTANCE BETWEEN FRAMES	RAM STROKE	DAYLIGHT	THROAT DEPTH	BED HEIGHT	BED CAP WIDTH (STANDARD)	BED CAP WIDTH (OPTIONAL)	# SLIDING FRONT SUPPORT ARMS	MOTOR POWER	OIL TANK CAPACITY
	(US)	A	B	C	D	E	F	G1	G2	QTY		
	Tons	Feet	Feet	Inch	Inch	Inch	Inch	Inch	Inch	Pcs.	HP	Gal
B-SMART 6-70	70	6' 10"	5' 7"	11"	20.9"	16.1"	35.4"	4"	7"	2	10	40
B-SMART 8-110	110	8' 6"	7' 3"	11"	20.9"	16.1"	35.4"	4"	7"	2	10	40
B-SMART 10-110	110	10' 2"	8' 6"	11"	20.9"	16.1"	35.4"	4"	7"	2	10	40
B-SMART 10-150	150	10' 2"	8' 6"	11"	20.9"	16.1"	35.4"	4"	7"	2	15	53
B-SMART 10-200	200	10' 2"	8' 6"	11"	20.9"	16.1"	35.4"	4"	10"	2	20	53
B-SMART 12-200	200	12' 4"	10' 8"	11"	20.9"	16.1"	35.4"	4"	10"	2	20	53
B-SMART 14-200	200	14' 0"	12' 4"	11"	20.9"	16.1"	35.4"	4"	10"	2	20	53
B-SMART 10-250	250	10' 2"	8' 6"	11"	20.9"	16.1"	35.4"	4"	10"	2	25	79
B-SMART 12-250	250	12' 4"	10' 8"	11"	20.9"	16.1"	35.4"	4"	10"	2	25	79
B-SMART 14-250	250	14' 0"	12' 5"	11"	20.9"	16.1"	35.4"	4"	10"	2	25	79
B-SMART 20-250	250	20' 0"	16' 9"	11"	20.9"	16.1"	43.3"	6"	12"	4	25	79
B-SMART 10-350	350	10' 2"	8' 6"	15"	24.8"	16.1"	35.4"	6"	12"	2	40	106
B-SMART 12-350	350	12' 4"	10' 8"	15"	24.8"	16.1"	35.4"	6"	12"	2	40	106
B-SMART 14-350	350	14' 0"	12' 4"	15"	24.8"	16.1"	35.6"	6"	12"	2	50	79
B-SMART 20-350	350	20' 0"	16' 9"	15"	24.8"	16.1"	43.3"	6"	12"	4	40	106
B-SMART 12-440	440	13' 5"	11' 8"	15"	24.8"	20.1"	43.3"	6"	12"	2	40	106
B-SMART 14-440	440	14' 0"	12' 5"	15"	24.8"	20.1"	43.3"	6"	12"	2	40	106
B-SMART 20-440	500	20' 0"	16' 9"	15"	24.8"	20.1"	43.3"	6"	12"	4	50	119
B-SMART 14-550	500	14' 0"	12' 5"	15"	24.8"	20.1"	43.3"	6"	12"	2	50	119
B-SMART 20-550	550	20'	16' 9"	15"	24.8"	20.1"	47.2"	6"	12"	4	50	132

Due to ongoing product development, machine specifications can change at any time.

Extra daylight, stroke, increased throat depths readily available

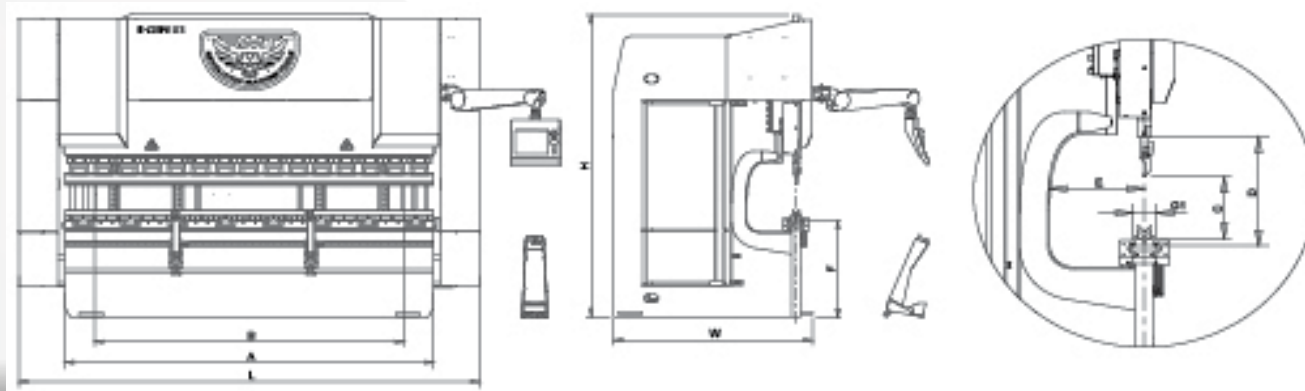

# B-SMART



B-SMART SERIES	RAM SPEEDS PROGRAMMABLE				BACK GAUGE SYSTEM						MACHINE DIMENSIONS			
	Y-AXIS APPROACH SPEED	Y-AXIS FORMING SPEED	DECOMPRESSION	Y-AXIS RETURN SPEED	X-AXIS SPEED	X-AXIS TRAVEL	3 <sup>RD</sup> GAUGEABLE FINGER POSITION	R-AXIS MAX SPEED	R-AXIS TRAVEL	# BACKGAUGE FINGER BLOCKS	LENGTH	WIDTH	HEIGHT	APPROX. WEIGHT
	Prog.	Prog.	Prog.	Prog.	Prog.	Prog.	Prog.	Std.	Std.	QTY	L	W	H	lbs
	I.P.M.	I.P.M.	I.P.M.	I.P.M.	I.P.M.	Inch	Inch	I.P.M.	Inch	Pcs.	Inch	Inch	Inch	lbs
B-SMART 6-70	94-472	0-24	0-24	94-472	5-1890	32.3"	41.7"	5-378	10.2"	2	128"	77"	108"	12,430
B-SMART 8-110	85-425	0-24	0-24	94-472	5-1890	32.3"	41.7"	5-378	10.2"	2	148"	77"	110"	15,070
B-SMART 10-110	85-425	0-24	0-24	94-472	5-1890	32.3"	41.7"	5-378	10.2"	2	167"	77"	110"	16,390
B-SMART 10-150	76-378	0-24	0-24	94-472	5-1890	32.3"	41.7"	5-378	10.2"	2	167"	85"	110"	19,030
B-SMART 10-200	66-331	0-21	0-21	85-425	5-1890	32.3"	41.7"	5-378	10.2"	2	167"	85"	110"	20,790
B-SMART 12-200	66-331	0-21	0-21	85-425	5-1890	32.3"	41.7"	5-378	10.2"	2	193"	85"	110"	24,090
B-SMART 14-200	66-331	0-21	0-21	85-425	5-1890	32.3"	41.7"	5-378	10.2"	2	208"	85"	112"	27,232
B-SMART 10-250	57-283	0-20	0-20	85-425	5-1890	32.3"	41.7"	5-378	10.2"	2	179"	89"	112"	25,300
B-SMART 12-250	57-283	0-20	0-20	85-425	5-1890	32.3"	41.7"	5-378	10.2"	2	201"	89"	114"	27,720
B-SMART 14-250	57-283	0-20	0-20	85-425	5-1890	32.3"	41.7"	5-378	10.2"	2	209"	89"	118"	32,120
B-SMART 20-250	47-236	0-20	0-20	85-425	5-1181	32.3"	41.7"	5-378	10.2"	4	295"	93"	126"	56,760
B-SMART 10-350	47-236	0-19	0-19	76-378	5-1890	32.3"	41.7"	5-378	10.2"	2	179"	97"	126"	36,960
B-SMART 12-350	47-236	0-19	0-19	76-378	5-1181	32.3"	41.7"	5-378	10.2"	2	201"	97"	124"	44,000
B-SMART 14-350	47-236	0-19	0-19	76-378	5-1181	32.3"	41.7"	5-378	10.2"	2	203"	81"	127"	50,089
B-SMART 20-350	43-213	0-19	0-19	76-378	5-1181	32.3"	41.7"	5-283	10.2"	4	295"	97"	132"	67,980
B-SMART 12-440	47-236	0-19	0-19	71-354	5-1181	40.2"	49.6"	5-283	10.2"	2	181"	85"	140"	55,116
B-SMART 14-440	47.236	0-19	0-19	71-354	5-1181	40.2"	49.6"	5-283	10.2"	2	221"	104"	137"	58,410
B-SMART 20-440	47-236	0-19	0-19	66-331	5-1181	40.2"	49.6"	5-283	10.2"	4	301"	104"	148"	87,340
B-SMART 14-550	43-213	0-18	0-18	66-331	5-1181	40.2"	49.6"	5-283	10.2"	2	211"	89"	146"	65,257
B-SMART 20-550	43-213	0-18	0-18	66-331	5-1181	40.2"	49.6"	5-283	10.2"	4	283"	89"	152"	89,067

Due to ongoing product development, machine specifications can change at any time.

