



HYDRAULIC

PRESSES

C-FRAME, H-TYPE, COLUMN FRAME,
WORKSHOP TYPE PRESSES





Some of the Revolution Machine Tools Team

ABOUT REVOLUTION MACHINE TOOLS

Revolution Machine Tools (RMT), founded by long time industry leader Kyle Jorgenson, is a metal fabrication machine tools company. RMT's design team has created the most innovative and precise tools in the North American market today. We are partners with leading manufacturers who build our designs to our stringent specifications in state of the art manufacturing facilities.

Kyle Jorgenson started in the Machine Tool industry working with his father, Roger Jorgenson, who founded Jorgenson Machine Tools in 1974. Roger taught Kyle how important relationships and customer service are, and Kyle has built his reputation on those principles. Revolution Machine Tools is supported by an ever expanding team of industry professionals, which include design, marketing, service and support, who have these same values and respect Kyle's vision. Together, they are creating a revolution in the Machine Tool industry.

RMT's main focus is in large cutting, forming, and rolling machines for the metal fabrication industry. RMT's research and development team has created the most innovative, fast, durable and accurate machines in the industry. Our machines are all backed by a strong warranty and an outstanding service team dedicated to keeping your machines operational. We understand the time value of money and how expensive downtime can be.





RMT offers several innovative machines including Fiber Lasers, Press Brakes, Plate Rolls, Ironworkers, Angle Rolls, Shears, Structural Steel Drills, Band Saws, Hydraulic Presses, Pipe Threading and Beveling, and much more. All RMT product designs are built for durability, precision, repeatability, and speed.

PRE-SALE CONSULTATION

RMT's commitment to service begins with our site assessment consultation. Before we even discuss purchasing equipment we make an assessment of your production area to determine whether the equipment will work well in your manufacturing environment. We look at where the equipment will be placed on the production floor, how it will be brought into the facility, and even ways to make the disposal of scrap and waste easier to remove. We will also recommend the proper installation of our equipment, or we can even come install it for you. More importantly, we can verify adequate electrical, pneumatic or hydraulic requirements and we look at the surrounding equipment to assess if there are any electro-magnetic or vibration interference issues.



We do all of these things because:
We take pleasure in helping make our customers businesses more successful.
Many of our customers have become life long friends that have carried over to several generations.

844-768-4636 / www.RMTUS.com 3



REVOLUTIONARY SERVICE

QUALIFIED SERVICE TECHNICIANS

Join the Revolution with service technicians from Revolution Machine Tools that can maintain, troubleshoot and fix your machines. Our goal at RMT is to ensure our customers experience smooth operations and greater return on investment by having their machines repaired and maintained by qualified personnel who are committed to the customer's success.

The service team at Revolution Machine Tools is experienced and able to diagnose, repair and install your equipment when you need it. We know that you can't wait for days or weeks to keep your production deadlines, and we are committed to minimizing your downtime and keeping your manufacturing processes moving forward.

PREVENTATIVE MAINTENANCE PROGRAM

Keeping your machines operating at their peak performance is key to successful manufacturing. At Revolution Machine Tools, we have the right preventative maintenance plan to fit your needs; thus, keeping your machines performing at their most efficient levels.



Our service technicians will create the perfect preventative maintenance plan for you. They will evaluate your machines and provide you with a customized maintenance plan. Each plan will include general maintenance, safety evaluations, suggested repairs and part replacement.

SERVICE WHEN YOU NEED IT

You can count on Revolution Machine Tools to be there when you need them. How many times have you needed customer service for a machine breakdown? Each and every breakdown equates to a loss in opportunity cost and profit. At Revolution Machine Tools, we are committed to making sure you get the most out of your equipment, and when it does breakdown, providing repair services in a timely manner.

So, if you are in need of a troubleshooting or repair, you can reach a service technician by phone or email and we will strive to respond quickly. You don't need help in two days, you need it now. You can count on Revolution Machine Tools because we are committed to getting you up and running when and where you need us.



PARTS & TOOLING



SUPERIOR PARTS AND TOOLING

Every machine used in the chipping, fabrication and forming of metal has consumables and tooling to keep them performing efficiently. These consumables and tools range from hydraulic oil, laser nozzle tips, replacement parts, software and more. Making sure you have the right products to take care of your machines is what we at Revolution Machine Tools specialize in. We stock the highest grade consumables, replacement parts and tooling to fit your needs; and, if on the rare occasion we don't have the part, we most likely know where to find it.

Our parts and tooling department is constantly looking for ways to maximize the potential of your machines. Specialized tooling can be ordered and shipped to your location. We have qualified customer service representatives who can help you find solutions and answers to your manufacturing needs.

Revolution Machine Tools and its staff are committed to providing you the most effective service possible. We encourage you to call, even if we don't carry your brand of machine, and see if we can support you in making sure you have the right parts and tooling to fulfill your production goals and needs.

REPLACEMENT PARTS AND ACCESSORIES



GERMAN HYDRAULIC SYSTEMS



HYDRAULIC PARTS



CUSTOM DIE SETS



BENEFITS OF RMT HYDRAULIC PRESSES

RMT has a reputation of building machines for long lasting durability, precision, repeatability, and speed. Our hydraulic presses are no different. They have been designed and built from the highest quality components to maintain accuracy with durable frameworks made from steel welded plate for long-lasting service.

Whether your application requires bending, straightening, forming, compacting, compressing, punching, stamping, trimming, deep drawing, hot forming, or any type of general forming, RMT has you covered. We have designed and produced an extensive line of hydraulic presses to match your needs. We also recognize the variety of industries who use our hydraulic presses and that is why we have many solutions available or we can configure a machine perfectly to match your needs and requirements.

Hydraulic Press Tonnage Available but Not Limited To:

- **Deep Drawing Presses**
Up to 3300 Tons
- **Forming Presses**
Up to 3300 Tons
- **Hot Plated Presses**
Up to 3300 Tons
- **Column Type Presses**
Up to 1100 Tons
- **Portal Type Presses**
Up to 1100 Tons
- **Workshop Presses**
Up to 550 Tons
- **C Type Presses**
Up to 275 Tons



Industries Using Hydraulic Presses:

- Agriculture
- Aerospace
- Automotive
- Coal Mining Equipment
- Defense
- Electrical Equipment
- Major Appliances
- Marine & Offshore Systems
- Military Application
- Pulp & Paper Manufacturing
- Small Workshops
- Steel Door Production
- Wind Turbine Manufacturing

HYDRAULIC PRESS SERIES



C-FRAME PRESSES

Single action presses

Produced up to 275 Tons

H-FAB C Series See pages 8, 9

H-SMART C Series See pages 10, 11



H-TYPE PRESSES

Deep drawing presses

Produced up to 3300 Tons

H-FAB HDT Series See pages 12, 13

H-SMART HSA Series See pages 14, 15



COLUMN FRAME PRESSES

Single action presses

Produced up to 1100 Tons

H-SMART HCFP Series See pages 16, 17



WORKSHOP TYPE PRESSES

Straightening presses

Produced up to 3300 Tons

H-FAB H Series See pages 18, 19

H-FAB HBP Series See pages 20, 21

H-FAB HPP Series See pages 22, 23





C FRAME SINGLE ACTION PRESSES

Produced up to 275 Tons capacity, C type presses are normally of standard size, yet can be produced according to customer requirements. C type presses can be used to bend, hole punch, cut and straighten according to the die cut used. Since the 3 sides are open, die cut mounting and disassembly can be done easily. C type presses, which are preferred for users who work with smaller die cuts, are produced to be automatic or manual.



H-FAB C Series

STANDARD

- Chrome plated cylinder
- Steel welded frame
- Safety cover and light barrier
- Two hand button control
- Adjustable pressure by regulator
- Adjustable stroke by sensor
- Oil pressure gauge
- Air cooling
- T-slotted table
- Common off the shelf components, typically of German or USA origin (Rexroth, Parker, Sneyders, and Seimens)

OPTIONAL

- HMI touch screen panel
- Die sets

We do not source any component of our presses from China

H-FAB C SERIES



Any open height, bed size, stroke are readily available upon customer request

| H-FAB C SERIES STANDARD SPECIFICATIONS | | H-FAB C33 | H-FAB C66 | H-FAB C110 | H-FAB C165 | H-FAB C220 | H-FAB C275 |
|--|--------|-----------|-----------|------------|------------|------------|------------|
| Ton | (US) | 33 | 66 | 110 | 165 | 220 | 275 |
| Table Size (L x W) | Inch | 20" x 20" | 20" x 20" | 32" x 20" | 32" x 24" | 36" x 24" | 40" x 24" |
| Daylight | Inch | 24" | 24" | 24" | 24" | 24" | 24" |
| Stroke | Inch | 16" | 16" | 16" | 16" | 16" | 16" |
| Closed Height | Inch | 8" | 8" | 8" | 8" | 8" | 8" |
| Motor Power | HP | 5 | 7.5 | 10 | 10 | 15 | 15 |
| Pump | Gallon | 2 | 3 | 9 | 9 | 9 | 12 |
| Down Speed | I.P.M. | 24" | 28" | 28" | 28" | 21" | 21" |
| Return Speed | I.P.M. | 40" | 50" | 43" | 50" | 43" | 43" |
| Working Speed | I.P.M. | 24" | 24" | 24" | 19" | 24" | 19" |
| Length | Inch | 59" | 59" | 67" | 67" | 75" | 79" |
| Width | Inch | 55" | 55" | 59" | 63" | 67" | 63" |
| Height | Inch | 91" | 91" | 106" | 114" | 114" | 114" |
| Weight (lbs) | lbs | 4,409 | 5,291 | 11,023 | 22,046 | 28,660 | 30,865 |

Due to ongoing product development, machine specifications can change at any time.



C FRAME SINGLE ACTION PRESSES

RMT C type deep drawing presses, which are produced to up to 275 Tons capacity, can be customized and made up to a certain size of a table depending on the customers requirements. The frame is in the form of a C and because of its shape, the space in the frame increases and this causes the frame to flex. The C type presses can be used to bend, hole punch, cut and straighten according to die set used.

This type of press is preferred for deep drawing processes with small die sets, as it takes up less space in production. In addition, the ejector roller placed in the top table for the work makes the product easier and quicker to remove after the drawing process is finished.

High precision processed frame and table provide our customers to receive precise products in their production.

H-SMART C Series

STANDARD

- Chrome plated cylinder
- Steel welded frame
- Servo hydraulic system
- HMI touch screen control panel
- Safety cover and light barrier
- Two hand button control
- Adjustable variable pressure on HMI touch screen control panel
- Adjustable stroke on HMI touch screen control panel
- Adjustable variable speed on HMI touch screen control panel
- Oil pressure gauge
- Air cooling
- T-slotted table and ram
- Common off the shelf components, typically of German or USA origin (Rexroth, Parker, Sneiders, and Seimens)

OPTIONAL

- Ejector cylinder
- Variable speeds
- Die sets
- Cushion
- Heated platens



We do not source any component of our presses from China

10 www.RMTUS.com / 844-768-4636

H-SMART C SERIES



Shown with optional cushion system



Any open height, bed size, stroke are readily available upon customer request

| H-SMART C SERIES STANDARD SPECIFICATIONS | | H-SMART C33 | H-SMART C66 | H-SMART C110 | H-SMART C165 | H-SMART C220 | H-SMART C275 |
|--|--------|-------------|-------------|--------------|--------------|--------------|--------------|
| Ton | (US) | 33 | 66 | 110 | 165 | 220 | 275 |
| Table Size (L x W) | Inch | 20" x 20" | 20" x 20" | 32" x 20" | 32" x 24" | 36" x 24" | 40" x 24" |
| Daylight | Inch | 20" | 20" | 20" | 20" | 20" | 20" |
| Stroke | Inch | 16" | 16" | 16" | 16" | 16" | 16" |
| Closed Height | Inch | 4" | 4" | 4" | 4" | 4" | 4" |
| Motor Power | HP | 10 | 10 | 15 | 15 | 20 | 20 |
| Pump | Gallon | 6 | 6 | 7 | 11 | 17 | 17 |
| Down Speed | I.P.M. | 236" | 236" | 236" | 260" | 295" | 295" |
| Return Speed | I.P.M. | 354" | 354" | 378" | 354" | 426" | 426" |
| Working Speed | I.P.M. | 24" | 24" | 24" | 20" | 24" | 20" |
| Optional Cushion Stroke | Inch | 6" | 6" | 6" | 6" | 6" | 6" |
| Length | Inch | 59" | 59" | 63" | 83" | 83" | 83" |
| Width | Inch | 55" | 55" | 67" | 71" | 71" | 75" |
| Height | Inch | 102" | 138" | 115" | 134" | 134" | 142" |
| Weight | lbs | 5,512 | 7,716 | 12,125 | 26,456 | 28,660 | 30,865 |

Due to ongoing product development, machine specifications can change at any time.



H TYPE HYDRAULIC PRESSES

RMT H type presses are produced to up to 330 Tons capacity and can be customized and produced according to the customer's needs and requirements. H type presses can be used to bend, shape, hole punch, cut and straighten according to the die cut used. If required, die cut loading devices or other die cut installation solutions are recommended to install the die cut.

High precision machined frame and tables allows you to receive precise products in your production.

H-FAB HDT Series



STANDARD

- Chrome plated cylinder
- Steel welded frame
- Pressure adjustment
- Oil pressure gauge
- T-slotted table
- Common off the shelf components, typically of German or USA origin (Rexroth, Parker, Sneyders, and Siemens)

OPTIONAL

- Ejector cylinder
- HMI touch screen control panel with RMT height suspension arm
- Die sets
- Heated platens
- Text alignment

We do not source any component of our presses from China

H-FAB HDT SERIES



Any open height, bed size, stroke are readily available upon customer request

| H-FAB HDT SERIES STANDARD SPECIFICATIONS | | H-FAB HDT110 | H-FAB HDT165 | H-FAB HDT220 | H-FAB HDT275 | H-FAB HDT330 |
|--|--------|--------------|--------------|--------------|--------------|--------------|
| Ton | (US) | 110 | 165 | 220 | 275 | 330 |
| Table Size (L x W) | Inch | 32" x 24" | 40" x 24" | 42" x 24" | 60" x 24" | 60" x 24" |
| Daylight | Inch | 24" | 24" | 24" | 24" | 24" |
| Stroke | Inch | 16" | 16" | 16" | 16" | 16" |
| Closed Height | Inch | 8" | 8" | 8" | 8" | 8" |
| Motor Power | HP | 5 | 7 | 20 | 20 | 20 |
| Pump | Gallon | 3 | 4 | 9 | 12 | 16 |
| Down Speed | I.P.M. | 17" | 14" | 21" | 26" | 31" |
| Return Speed | I.P.M. | 31" | 24" | 40" | 45" | 61" |
| Working Speed | I.P.M. | 17" | 17" | 21" | 26" | 31" |
| Length | Inch | 39" | 39" | 47" | 47" | 51" |
| Width | Inch | 51" | 55" | 98" | 106" | 106" |
| Height | Inch | 91" | 91" | 102" | 102" | 106" |
| Weight | lbs | 5,512 | 6,614 | 8,157 | 14,330 | 17,637 |

Due to ongoing product development, machine specifications can change at any time.



H TYPE SINGLE ACTION PRESSES

RMT H type presses are produced to up to 3300 Tons capacity and can be customized and produced according to the customer's needs and requirements. H type presses can be used to bend, shape, hole punch, cut and straighten according to the die cut used. If required, die cut loading devices or other die cut installation solutions are recommended to install the die cut.

High precision machined frame and tables allows you to receive precise products in your production.

H-SMART HSA Series



STANDARD

- Chrome plated cylinder
- Steel welded frame
- Servo proportional hydraulic system
- HMI touch screen control panel with RMT height suspension arm
- Safety cover and light barrier
- Two hand button control
- Adjustable variable pressure on HMI touch screen control panel
- Adjustable stroke on HMI touch screen control panel
- Oil pressure gauge
- Lubrication
- Air cooling
- T-slotted table
- Common off the shelf components, typically of German or USA origin (Rexroth, Parker, Sneyders, and Seimens)

OPTIONAL

- Ejector cylinder
- Variable speeds
- Tool loading device
- Die sets
- Cushion
- Heated platens

We do not source any component of our presses from China

H-SMART HSA SERIES



Shown with optional cushion



Shown with optional forming pad box

Any open height, bed size, stroke are readily available upon customer request

| H-SMART HSA SERIES STANDARD SPECIFICATIONS | | H-SMART HSA110 | H-SMART HSA220 | H-SMART HSA330 | H-SMART HSA440 | H-SMART HSA550 | H-SMART HSA660 | H-SMART HSA880 | H-SMART HSA1100 | H-SMART HSA1650 | H-SMART HSA2200 | H-SMART HSA3300 |
|--|--------|-------------------------|----------------|----------------|----------------|----------------|----------------|--|-----------------|-----------------|-----------------|-----------------|
| Ton | (US) | 110 | 220 | 330 | 440 | 550 | 660 | 880 | 1100 | 1650 | 2200 | 3300 |
| Table Size (L x W) | Inch | 32" x 40" | 32" x 40" | 40" x 48" | 47" x 55" | 47" x 59" | 59" x 67" | Request a quote - Table size can be customized | | | | |
| Daylight | Inch | 48" | 48" | 48" | 48" | 48" | 48" | | | | | |
| Stroke | Inch | 40" | 40" | 40" | 40" | 40" | 40" | | | | | |
| Closed Height | Inch | 8" | 8" | 8" | 8" | 8" | 8" | | | | | |
| Motor Power | HP | 30 | 30 | 30 | 40 | 40 | 50 | | | | | |
| Pump | Gallon | 13 | 13 | 23 | 31 | 31 | 56 | | | | | |
| Down Speed | I.P.M. | 234" | 234" | 234" | 234" | 234" | 234" | | | | | |
| Return Speed | I.P.M. | 330" | 330" | 330" | 330" | 330" | 330" | | | | | |
| Working Speed | I.P.M. | 36" | 24" | 24" | 24" | 24" | 36" | | | | | |
| Optional Cushion Tonnage | (US) | 44 | 70 | 140 | 165 | 220 | 275 | | | | | |
| Optional Cushion Stroke | Inch | 12" | 12" | 12" | 12" | 12" | 12" | | | | | |
| Optional T-Slots | | To customer requirement | | | | | | | | | | |
| Length | Inch | 87" | 87" | 95" | 102" | 102" | 118" | | | | | |
| Width | Inch | 83" | 83" | 91" | 98" | 98" | 110" | | | | | |
| Height | Inch | 165" | 165" | 177" | 185" | 193" | 217" | | | | | |
| Weight | lbs | 17,637 | 22,046 | 33,069 | 44,093 | 50,706 | 66,139 | | | | | |
| Weight with Cushion Option | lbs | 19,842 | 26,456 | 37,479 | 50,706 | 57,320 | 72,753 | | | | | |

Due to ongoing product development, machine specifications can change at any time.

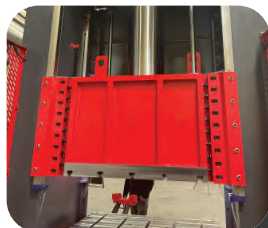



COLUMN FRAME SINGLE ACTION PRESSES

Produced up to 1100 Tons capacity, the RMT column frame presses are standard in size and can be customized and produced according to customer needs and requirements. Column type presses can be used to bend, shape, hole punch, cut, and straighten according to the used die cut. If required, die cut loading system or other die cut installation solutions are recommended to install the die cut.

High precision processed frame and table provide our customers to receive precise products in their production

H-SMART HCFP Series



STANDARD

- Chrome plated cylinder
- Steel welded frame
- Tie-rod frame
- HMI touch screen control panel
- Safety cover and light barrier
- Two hand button control
- Adjustable variable pressure on HMI touch screen control panel
- Adjustable stroke on HMI touch screen control panel
- Oil pressure gauge
- Air cooling
- T-slotted table and ram
- Common off the shelf components, typically of German or USA origin (Rexroth, Parker, Sneiders, and Siemens)

OPTIONAL

- Ejector cylinder
- Variable speeds
- Cushion
- Tool loading device
- Heated platens

We do not source any component of our presses from China

H-SMART HCFP SERIES



Any open height, bed size, stroke are readily available upon customer request

| H-SMART HCFP SERIES STANDARD SPECIFICATIONS | | H-SMART HCFP110 | H-SMART HCFP220 | H-SMART HCFP330 | H-SMART HCFP440 | H-SMART HCFP550 | H-SMART HCFP880 | H-SMART HCFP1100 |
|---|--------|-----------------|-----------------|-----------------|-----------------|-----------------|-----------------|------------------|
| Ton | (US) | 110 | 220 | 330 | 440 | 550 | 880 | 1100 |
| Table Size (L x W) | Inch | 32" x 40" | 32" x 40" | 40" x 47" | 47" x 55" | 47" x 59" | Request a quote | |
| Daylight | Inch | 48" | 48" | 48" | 48" | 48" | | |
| Stroke | Inch | 39.4" | 39.4" | 39.4" | 39.4" | 39.4" | | |
| Closed Height | Inch | 8.6" | 8.6" | 8.6" | 8.6" | 8.6" | | |
| Motor Power | HP | 30 | 30 | 30 | 40 | 40 | | |
| Pump | Gallon | 13 | 13 | 23 | 31 | 31 | | |
| Down Speed | I.P.M. | 234" | 234" | 234" | 234" | 234" | | |
| Return Speed | I.P.M. | 330" | 330" | 330" | 330" | 330" | | |
| Working Speed | I.P.M. | 36" | 20" | 24" | 24" | 20" | | |
| Length | Inch | 87" | 87" | 95" | 102" | 102" | | |
| Width | Inch | 83" | 83" | 91" | 98" | 98" | | |
| Height | Inch | 165" | 165" | 177" | 185" | 193" | | |
| Weight | lbs | 17,637 | 22,046 | 33,069 | 44,093 | 50,706 | | |

Due to ongoing product development, machine specifications can change at any time.



HYDRAULIC WORKSHOP TYPE PRESSES

RMT H-FAB H presses come in standard sizes and can be customized and produced according to customer purpose. These are workshop-type presses and can be manufactured up to 1100 Tons in automatic and manual as optional. They are used mostly in repair and maintenance workshops for the small bending, punching, straightening, extracting/removing.

H-FAB H Series



STANDARD

- Chrome plated cylinder
- Steel welded frame
- Oil pressure gauge
- Pressure adjustment
- 2 speed hydraulics
- Large ram stroke
- Movable cylinder (left to right)
- V-block with working plate
- Common off the shelf components, typically of German or USA origin (Rexroth, Parker, Sneiders, and Seimens)

OPTIONAL

- Pressure adjustment
- Palm buttons, automatic functions
- Hydraulic movable cylinder motion by an additional hydraulic cylinder
- Die sets
- Stroke, open height and widths
- Included press
- Rolling bolsters
- Platens

OPTIONAL FEATURES



Palm Buttons -
Automatic Functions



Hydraulic Left-Right
Movement of Head



Pressure Adjustment

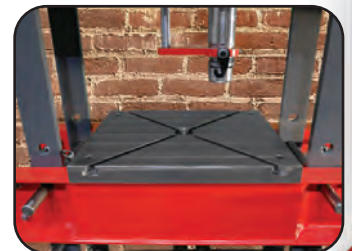

Platens

We do not source any component of our presses from China

H-FAB H SERIES



Custom machines available in different daylight, closed height, stroke and tonnage to 330 ton.
Available with vertical, horizontal or inclined frames. Also available with rolling bolsters.

| H-FAB H SERIES STANDARD SPECIFICATIONS | | H-FAB H65 | H-FAB H90 | H-FAB H110 | H-FAB H130 | H-FAB H180 | H-FAB H200 | H-FAB H220 | H-FAB H275 | H-FAB H330 | H-FAB H440 | H-FAB H550 |
|--|------|------------|-----------|------------|------------|------------|------------|------------|------------|------------|------------|------------|
| Ton | (US) | 65 | 90 | 110 | 130 | 180 | 200 | 220 | 275 | 330 | 440 | 550 |
| Clear Front | D | Inch 32" | 36" | 40" | 47" | 43" | 61" | 51" | 51" | 55" | 55" | 55" |
| Clear Side | E | Inch 12" | 12" | 12" | 16" | 14" | 22" | 18" | 18" | 22" | 22" | 22" |
| Stroke | | Inch 16" | 16" | 16" | 16" | 16" | 16" | 16" | 16" | 16" | 16" | 16" |
| Daylight | H | Inch 35.4" | 35.4" | 35.4" | 35.4" | 35.4" | 35.4" | 35.4" | 35.4" | 35.4" | 35.4" | 35.4" |
| Motor Power | | HP 4 | 4 | 5 | 5 | 7 | 10 | 10 | 20 | 20 | 40 | 40 |
| Down Speed | | I.P.M. 15" | 13" | 17" | 14" | 15" | 20" | 15" | 21" | 24" | 24" | 21" |
| Return Speed | | I.P.M. 24" | 20" | 32" | 23" | 24" | 32" | 27" | 31" | 48" | 64" | 46" |
| Foot Length | B | Inch 34" | 35" | 35" | 39" | 39" | 47" | 47" | 47" | 59" | 59" | 51" |
| Foot Width | C | Inch 47" | 52" | 52" | 64" | 54" | 77" | 72" | 86" | 86" | 87" | 87" |
| Width | | Inch 58" | 61" | 63" | 75" | 65" | 88" | 83" | 97" | 97" | 98" | 98" |
| Height | A | Inch 95" | 95" | 97" | 97" | 100" | 112" | 112" | 104" | 130" | 130" | 130" |
| Voltage | | PH 1 | 3 | 3 | 3 | 3 | 3 | 3 | 3 | 3 | 3 | 3 |
| Weight | | lbs 1,543 | 1,598 | 2,205 | 2,756 | 2,866 | 4,630 | 5,732 | 6,834 | 9,921 | 14,330 | 18,739 |

Due to ongoing product development, machine specifications can change at any time.

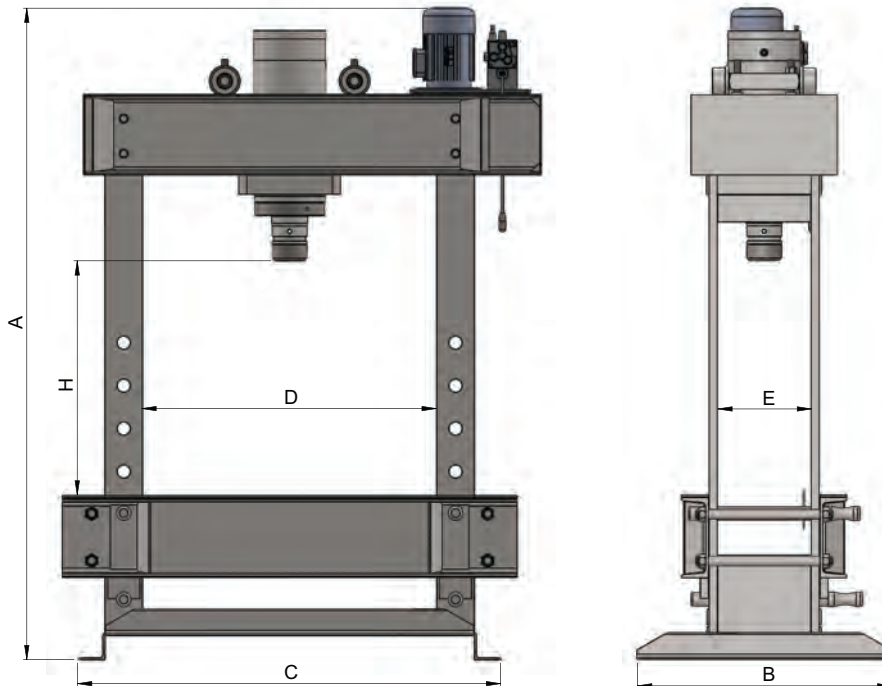

V-Blocks



Hydraulic System



Integrated Lifting Eye



Hardened Ram Nose with Easy Change Tools



HYDRAULIC WORKSHOP TYPE PRESSES

RMT's H-FAB HBP is a high quality built workshop press brake that is a small but powerful single axis press brake. It is a cost effective solution for small bending jobs and prototyping. These presses are produced to up to 330 Tons capacity and can be customized and produced according to the customer's needs and requirements.

H-FAB HBP Series



STANDARD

- Chrome plated cylinder
- Steel welded frame
- Oil pressure gauge
- Pressure adjustment
- Tool
- Manual back gauge
- Press brake tooling
- Common off the shelf components, typically of German or USA origin (Rexroth, Parker, Sneiders, and Seimens)

OPTIONAL

- NC control
- Variable speeds
- Foot pedal control

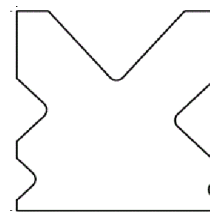

5 way die

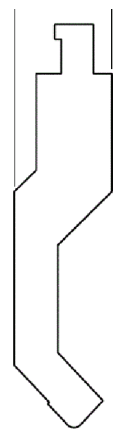

Included Punch

We do not source any component of our presses from China

20 www.RMTUS.com / 844-768-4636

H-FAB HBP SERIES



Any open height, bed size, stroke are readily available upon customer request

| H-FAB HBP SERIES STANDARD SPECIFICATIONS | | H-FAB HBP110 | H-FAB HBP165 | H-FAB HBP220 | H-FAB HBP275 | H-FAB HBP330 |
|--|--------|--------------|--------------|--------------|--------------|--------------|
| Ton | (US) | 110 | 165 | 220 | 275 | 330 |
| Bending Length | Inch | 39" | 47" | 79" | 79" | 79" |
| Stroke | Inch | 16" | 16" | 16" | 16" | 16" |
| Daylight | Inch | 21" | 21" | 21" | 21" | 21" |
| Motor Power | HP | 5 | 5 | 7 | 11 | 15 |
| Pump | Gallon | 3 | 3 | 8 | 10 | 14 |
| Down Speed | I.P.M. | 12" | 15" | 24" | 24" | 24" |
| Return Speed | I.P.M. | 17" | 21" | 43" | 43" | 43" |
| Working Speed | I.P.M. | 7" | 7" | 15" | 12" | 12" |
| Length | Inch | 75" | 79" | 114" | 114" | 114" |
| Width | Inch | 43" | 43" | 51" | 51" | 51" |
| Height | Inch | 98" | 102" | 108" | 108" | 108" |
| Weight | lbs | 4,409 | 5,512 | 8,819 | 9,921 | 13,228 |

Due to ongoing product development, machine specifications can change at any time.



HYDRAULIC PORTAL STRAIGHTENING PRESSES

RMT portal type presses are used to straighten large and long beams, plates, pipes, etc. These presses, which can be produced in requested size and tonnage, proved great convenience to user for they can work in 3 Axes. These presses are produced to up to 1100 Tons capacity and can be customized and produced according to the customer's needs and requirements.

H-FAB HPP Series



STANDARD

- Chrome plated cylinder
- Steel welded frame
- Controlled by pendant
- X, Y, Z Axis movement motorized
- Stroke control in any position
- Pressure adjustment
- Oil pressure gauge
- T-slotted table
- Working plate
- Common off the shelf components, typically of German or USA origin (Rexroth, Parker, Sneider, and Seimens)

OPTIONAL

- NC
- Larger open height and stroke
- Power rolling ram across rail (3 Axis powered movement)
- Digital position readout for any axis
- Different table configurations
- Wireless remote pendant

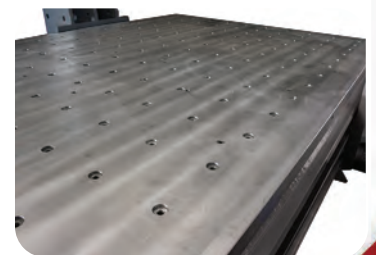
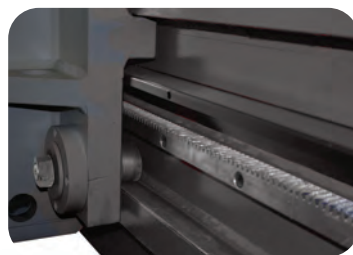

We do not source any component of our presses from China

H-FAB HPP SERIES



Can be built in basically any custom size

| H-FAB HPP SERIES STANDARD SPECIFICATIONS | | H-FAB HPP110 | H-FAB HPP220 | H-FAB HPP330 | H-FAB HPP440 |
|--|--------|--------------|--------------|--------------|--------------|
| Ton | (US) | 110 | 220 | 330 | 440 |
| Table Size (L x W) | Inch | 40" x 79" | 40" x 99" | 59" x 118" | 59" x 138" |
| Stroke | Inch | 16" | 16" | 16" | 16" |
| Daylight | Inch | 24" | 24" | 24" | 24" |
| Motor Power | HP | 5 | 10 | 20 | 24 |
| Down Speed | I.P.M. | 17" | 17" | 21" | 21" |
| Return Speed | I.P.M. | 31" | 24" | 40" | 45" |

Due to ongoing product development, machine specifications can change at any time.



Hydraulic Presses



Fiber Lasers

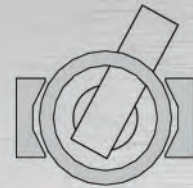

PSM Pipe Lathe



Press Brakes

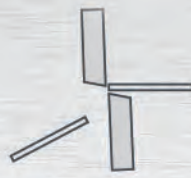

Shears

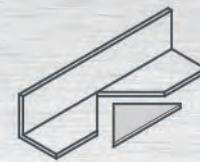

Ironworkers



Plate Rolls



Angle Rolls



Bandsaws



Dishing Presses

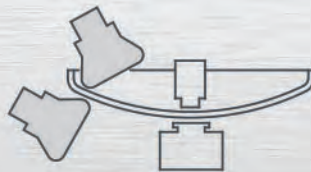

Flanging Machines



Drilling Machines

*"If you need a machine and don't buy it, you'll find that you have paid for it anyway, but don't have it."
Henry Ford*

Revolution Machine Tools
385 N 700 W
North Salt Lake, UT 84054

www.RMTUS.com
info@rmtus.com

Phone: 844.RMT.INFO
844.768.4636

KYSON

844-768-4636 / www.RMTUS.com