

# Revolution Machine Tools



<b>Main Warehouse</b>
<b>385 North 700 West</b>
<b>North Salt Lake City Ut. 84054</b>
<b>www.RMTUS.com</b>
<b>Sales:</b> Phone: (844)768-4636 info@rmtus.com
<b>Service:</b> Phone: (844)RMT-SERV (844)768-7378 service@rmtus.com
<b>Parts &amp; Tooling:</b> Phone (844) 768-4636 Talip@rmtus.com
Prepared by: Danny Semick

## Machine Specifications

<b>RMT Machine Stock Number:</b>		<b>Machine Dimensions and Weight</b>	
<b>Manufacture</b>	Niagra	<b>Length x Width x Height</b>	129" x 55" x 108"
<b>Type</b>	Press Brake HBR 135-8-10	<b>Machine Weight in Lbs.</b>	17000
<b>Model #</b>	HBR 135-8-10	<b>Incoming Power Requirements</b>	
<b>Serial #</b>	P53910	<b>Incoming Voltage</b>	3 PHASE 230V
<b>Mfg. Year</b>	1993	<b>Full Load Current Amps</b>	78
<b>Status:</b>	Used	<b>Min. Incoming Wire Size</b>	3
		<b>Recommended Breaker</b>	110
		<b>Horse Power</b>	<b>Main Motor 25</b>

## Machine Capacity - Capabilities

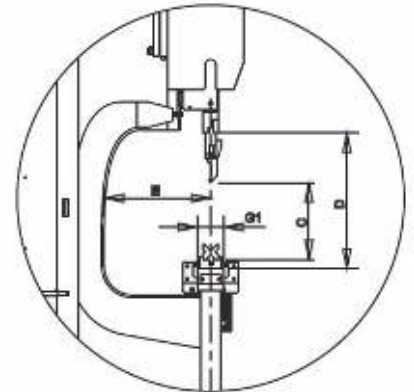
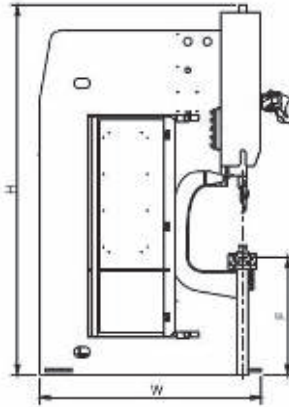
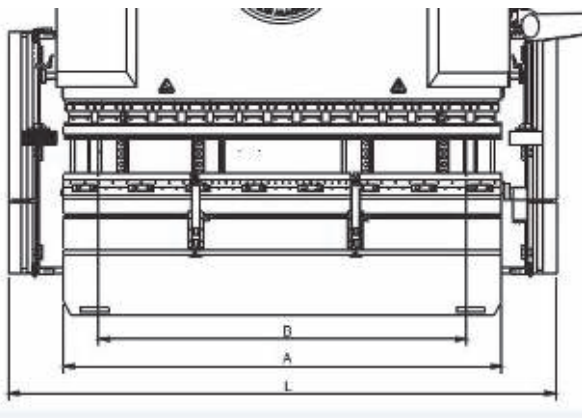

- Overall Bending Length (A) 124"
- Distance Between Frames (B) 8' 6"
- Stroke Length (C) 8"
- Daylight (D) 15"
- Throat Depth (E) 7"
- Table Height (F) 36"

All Information subject to Verification

If you have any questions Regarding this Specification sheet, please contact us at info@rmtus.com or (844) 768-4636

**Thank You For The Opportunity!**



Fiber Lasers



Press Brakes



Shears



Ironworkers



Bandsaws



Plate Rolls



Angle Rolls



Dishing Presses



Flanging Machines



Drilling Machines